

HC-Omega (Sinus Slide®) armour joints

Technical sheet

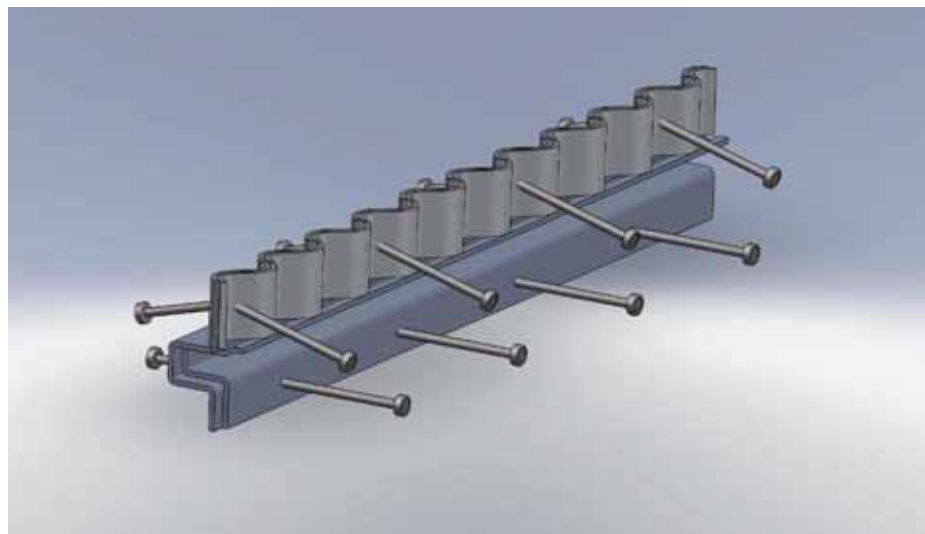

Table of Contents:

Description	3
Characteristics	4
Product overview.....	5
Technical specifications Product sheets	
HC-Omega 1 row of anchors.....	6
HC-Omega 2 rows of anchors	7
HC-Omega Sinus Slide ®.....	8
Accessories.....	9
Load transfer	10
Testing	11
Test setup.....	11
Test results.....	11
Sample calculation	12
Installation instructions	16
Maintenance and finishing.....	17

Description

The **HC-Omega** construction and expansion joint is made of two continuous cold-rolled profiles in 5 mm thick SJ235JRG2 steel. These profiles fit together tightly due to their clever, standardised form. For anchoring into concrete, these profiles are provided with $\varnothing 10$ mm, 125 mm long anchor bolts that are automatically welded on every 200 mm using resistance butt welding.

The top sides of the profiles are **milled** after being assembled to guarantee practically perfect flatness and straightness. The profiles are connected together using wing bolts with plastic nuts that do not need to be removed after being put in place. The profiles are assembled with an overlap of 15mm so that the next profile can easily be connected to the previous profile during installation.

The profile is made in standard lengths of 3 m and is available in heights from 120 to 300 mm. We provide custom solutions above 300 mm.

With their continuous form, these profiles prevent strain being concentrated during load transfer. ***This means that a higher and more smoothly load transfer is possible in comparison to discontinuous profiles.*** The patent pending Sinus Slide® joint with corrugated upper side in 5 mm thick steel ensures continuous support of passing wheels regardless of the direction, size and form of the wheel, from the placement of the joint to its maximum opening of 20 mm. By neutralising the striking impact of the wheels, forklift drivers experience unprecedented **comfort**. At the same time, maximum **edge protection and load transfer** are achieved, significantly reducing the chance of damage to the floor, the vehicle, or the goods being transported. This Sinus Slide® joint is especially recommended in thoroughfares and/or other areas of the floor that experience high forklift traffic. The Sinus Slide® Joints enables not only joint free floor slabs but the whole floor is experienced as Joint free. You can still see a joint but you don't feel it anymore. This is a new age in industrial flooring technology. This shock-and vibration free crossing will prevent any damage on your floor and save the investor huge amounts on wear and tear of forklifts. Only with the replacement costs of wheels the payback period of the investment is less than one year.

Characteristics

- **Free horizontal expansion and contraction** of the industrial floor. As the poured concrete dries, the inevitable contraction is taken up by the horizontal spreading of the HC-Omega expansion joint. This prevents the formation of cracks as a result of the drying process. This crack formation also occurs if a hole is cut into the floor too late, which is unnecessary with the installation of a dilatation joint.
- **Preventing vertical movement** The minute tolerances between the profiles and the typical Omega form connection prevent the slightest vertical movement between the separate floor sections that are created. The steel profiles also ensure the elastic behaviour of the joint.
- **Load transfer** With forklift traffic, the HC-Omega expansion joint provides a transfer of loads from one floor section to another. This means that the floor is less subject to wear, the chance of damage is reduced, and the lifetime of the industrial floor is lengthened considerably. The Sinus Slide® version realize this load transfer is a noiseless and smoothly way. The wheels of the forklifts are sliding shock- and vibration free from one floor section to another. This creates an unprecedented level of comfort.
- **Maximum load.** The rigid steel structure ensures that maximum loads are handled with minimum deformation.
- **Edge protection.** The 5 mm thick steel profiles and especially the Sinus Slide® joint give maximum edge protection. The Sinus Slide® joint will not only create an unprecedented level of comfort but will also avoid any crumbling of the edges of the floor sections.
- **Construction joint profile** The HC-Omega profiles are placed according to a layout plan with limited dimensions to separate the different floor sections. We advice floor slabs 30x30 meters in order to limit the opening gap of the joints to maximum 15 mm. The sections can then be poured and finished according to the daily schedule.
- **Easy installation and compatible.** The HC-Omega expansion joint is quite easy and quick to install according to the installation instructions given below in this technical documentation. The HC-Omega is 100% compatible with the HC-Omega Sinus Slide® Joint for every available height.
- **Compliant with the European directive 2002/44/EC.** The Sinus Slide® joint guarantees shock- and even vibration free transfer between two floor sections even with forklifts with very small and hard wheels. With this feature the HC-Sinus Slide® Joint is compliant with the European directive 2002/44/EC concerning exposures of workers to whole body vibrations.

Product overview

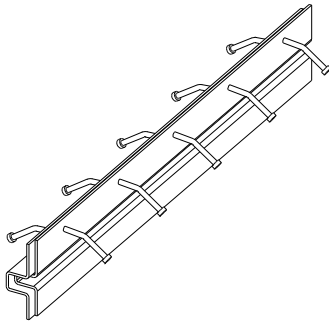

Type 1
HC-omega armour joint
with 2 x 1 row anchor
bolts

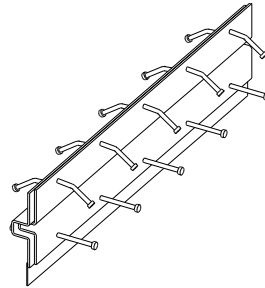

Type 2
HC-Omega armour joint
with 2 x 2 rows anchor
bolts

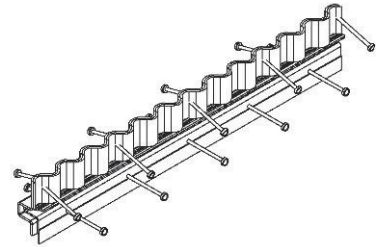

Type 3
HC-Omega Sinus Slide®
Joint with 2 x 2
row anchor bolts

Technical specifications of the HC-Omega armour joint			
	1	2	3
Thickness		2 x 5 mm	
Steel grade		SJ235JRG2	
Length	3 m	3 m	2.997 m
Type of anchor bolts	Ø10 lg 125 mm 2 x 5 pieces/m Automatically welded	Ø10 lg 125 mm 2 x 10 pieces/m Automatically welded	Ø10 lg 125 mm 2 x 10 pieces/m Automatically welded
Production	Cold rolled for optimal tolerances in construction		
Steel construction		Untreated natural steel electro-galvanized Stainless steel by request	
Profile height	120-200 mm Other dimensions by request	180-300 mm Other dimensions by request	120-300 mm Other dimensions by request
Finishing		Top side milled 15 mm overlap at the end for smooth connections	
Fastening	Attached with M6 x 20 wing bolts and polyamide plastic nuts. These attachments must not be removed after installation. The tensile force of the concrete breaks the connection with the polyamide nut.		
Concrete reinforcement	Both concrete with steel mesh and fibre reinforced concrete		
Fittings	T- and X-shaped intersections		
Auxiliary equipment	Tool for height adjustment and placement		
Straightness of horizontal surface		1 mm / 3 m	
Straightness of vertical surface		2 mm/3m	
Shock-free transfer	N	N	YES

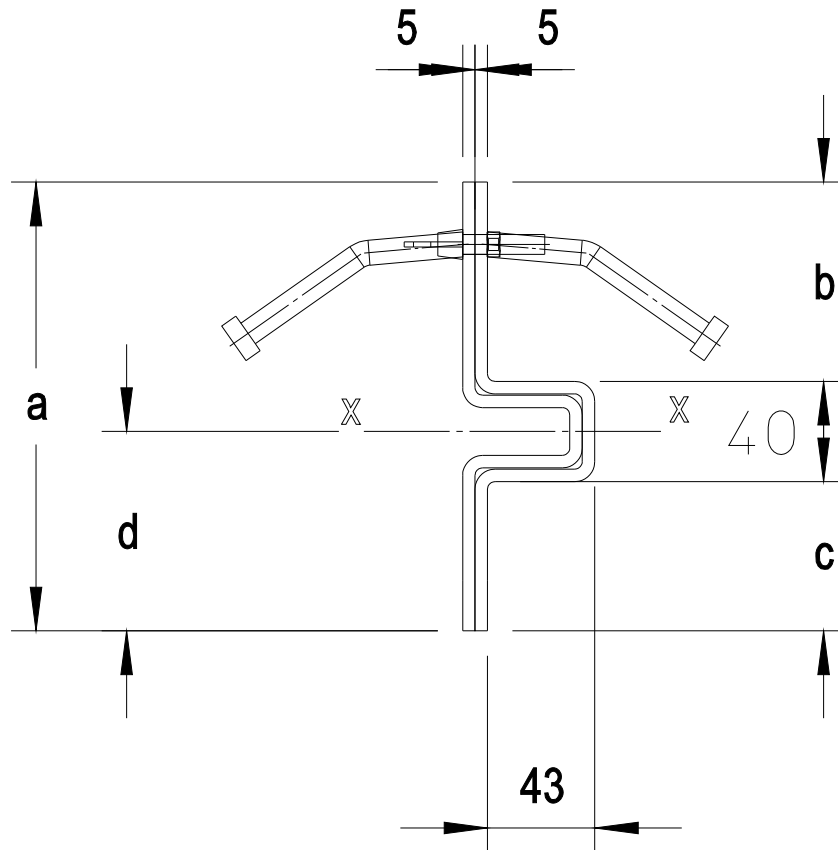

HC-Omega $a \times 5$, 2 x 1 row of anchor bolts								
Profile height a (mm)	Floor thickness (mm)	b (mm)	c (mm)	d (mm)	I _{xx} (cm ⁴)	W _{xx} (cm ³)	Weight kg/metre	Max metres per pallet
120	130-140	55	25	53.7	131	20	15,13	126
140	150-160	70	30	62.4	195	25	16.71	108
150	160-170	70	40	69.5	252	31	17,49	108
160	170-180	70	50	76.5	323	39	18,27	108
180	190-200	80	60	86.8	460	49	19,85	90
200	210-220	85	75	98.5	659	65	21,41	90

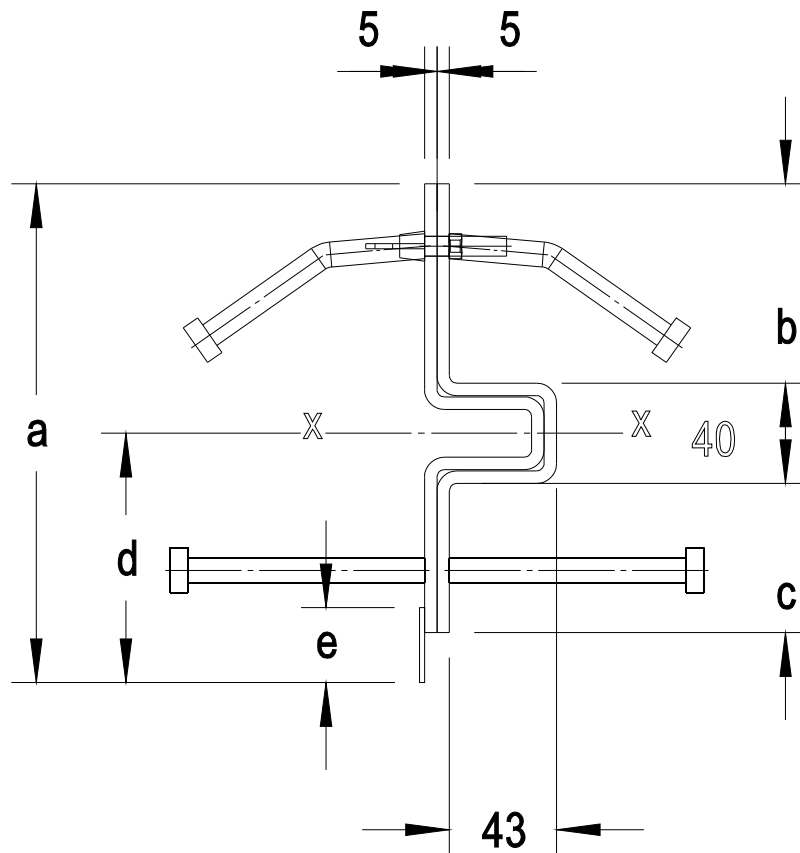

HC-Omega a x 5, 2 x 2 row of anchor bolts									
Profile height a (mm)	Floor thickness (mm)	B (mm)	C (mm)	D (mm)	E (mm)	I _{xx} (cm ⁴)	W _{xx} (cm ³)	Weight kg/metre	Max. metres per pallet
150	160-170	70	40	69.5	-	252	31	18,34	108
160	170-180	70	50	76.5	-	323	39	19,12	108
180	190-200	80	60	86.8	-	460	49	20,70	90
200	210-220	85	75	98.5	-	659	65	22,26	90
220	230-240	85	75	111.2	30	785	72	22,73	81
240	250-260	85	75	124.5	50	947	82	23,04	81
260	270-280	85	75	137.7	70	1154	94	23,35	63
280	290-300	85	75	150.9	90	1406	109	23,66	63
300	310-320	85	75	163.9	110	1705	125	23,97	63

Top view

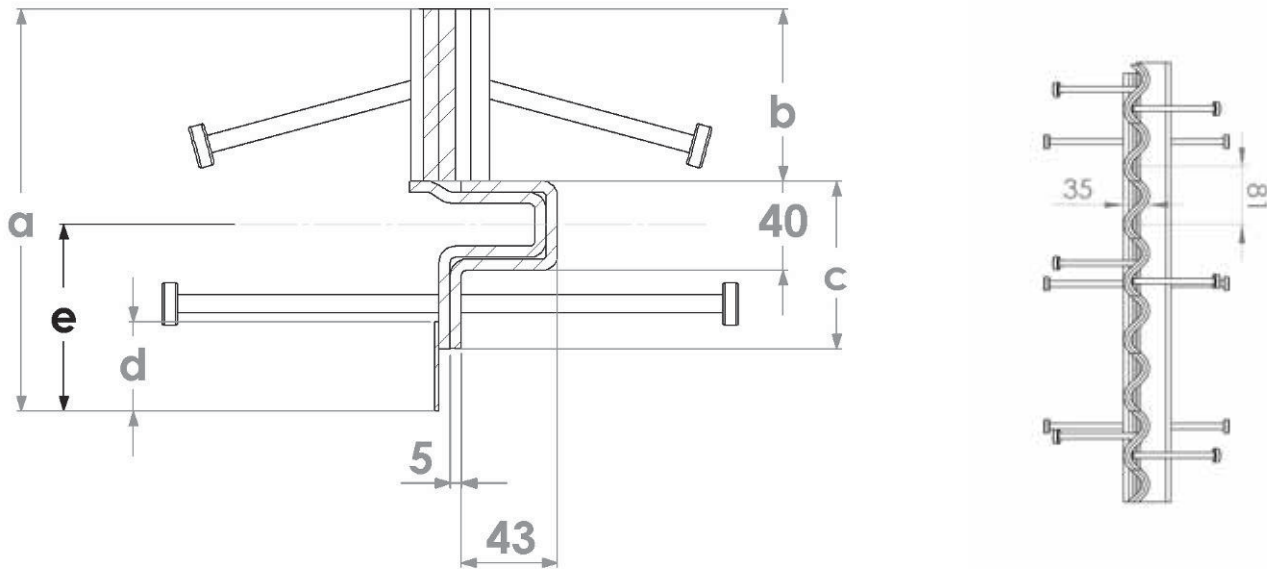

HC-Omega Sinus Slide® a x 5, 2 x 2 rows of anchors									
Profile height a (mm)	Floor thickness (mm)	b (mm)	c (mm)	D (mm)	E (mm)	Ixx (cm ⁴)	Wxx (cm ³)	Weight (kg/m)	Max. Metres pro pallet
120 (125)*	120-140	55	70	-	53.7	131	20	17,15	120
140	150-160	70	70	1	62.4	195	25	18,32	108
150	160-170	70	70	20	69.5	252	31	18,32	108
160	170-180	70	70	30	76.5	323	39	18,72	108
180	190-200	80	70	40	86.8	460	49	19,62	90
200	210-220	85	70	55	98.5	659	65	20,36	90
220	230-240	85	70	75	111.2	785	72	20,67	81
240	250-260	85	115	40	124.5	947	82	23,75	81
260	270-290	85	115	65	137.7	1154	94	24,14	81
280	290-300	85	115	85	150.9	1406	109	24,46	63
300	310-320	85	115	105	163.9	1705	125	24,77	63

* to make the Sinus Slide® joint compatible with the traditional straight HC-Omega joint the real height differs slightly.

Accessories

Junctions

These are available in all dimensions in proportion to the profile used.

X and T- crossings for traditional joints



X, T and L-crossings for Sinus Slide® joints

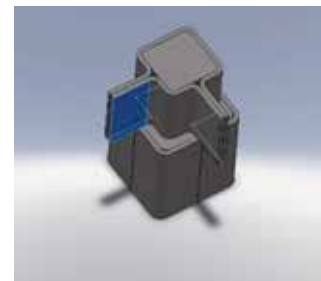
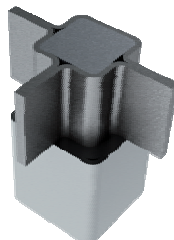
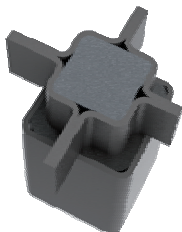

Assembly assistance



Load transfer

The load transfer by the profile depends on a number of factors

- A primary factor is a position variable. This indicates the position of the load relative to the joint and support.

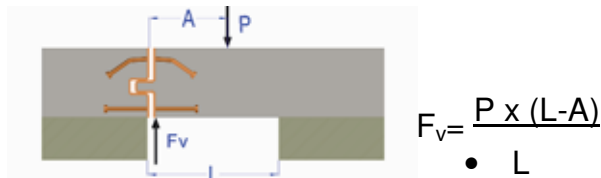

- A second factor is the size of the load in proportion to the thickness of the floor. Load transfer is only provided from the moment that the load is large enough to move or deform the floor section until any play between the sections has been taken up.

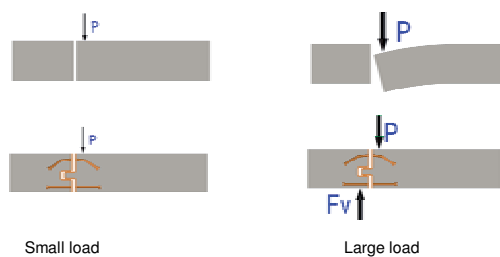

- A third factor that affects load transfer is the foundation. With a massive foundation, the loads will be supported by the foundation. In the case of a floor on piles, the load will have to be fully supported by the profile.

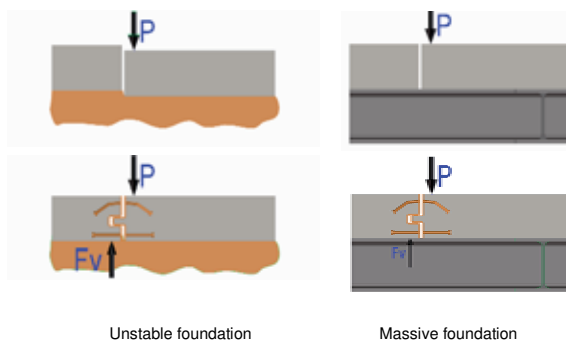

If a load is placed on the edge of a slab, the strain in the concrete is about 50% higher than a load in the middle of the slab. The expansion joint compensates this increase and will transfer up to 100% of this load to the adjoining slab, depending on the foundation, the position and size of the load.

Testing

The joints have been tested to their maximum capacity by the Magnel lab associated with the University of Ghent.

Test setup

It was decided to test the joint without support such that the load transfer through the joint was maximized.

The joint was placed in a test specimen with dimensions 1 m x 1.05 m.

The joint openings of 10 mm and 20 mm were tested.

For the concrete, a test was done with non-reinforced concrete (c30/37) and with fibre reinforced concrete (45 kg fibres/m³).

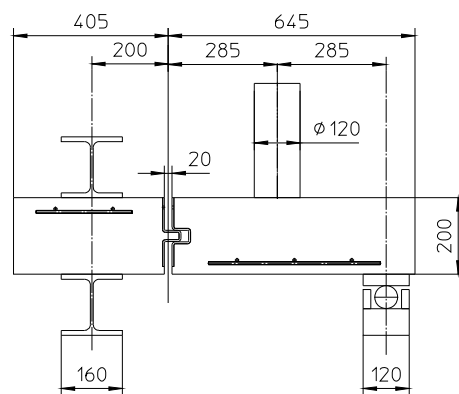

Test results

Type	Anchors upper/lower	Opening (mm)	Concrete height (mm)	Fibre reinforced concrete (y/n)	Failure load kN
HC-Omega 140	Upper	10	150	N	90
HC-Omega 140	Upper	20	150	N	120
HC-Omega 180	Upper	10	200	Y	160
HC-Omega 180	Upper	20	200	Y	197
HC-Omega 180	Upper + lower	10	200	Y	272
HC-Omega 180	Upper + lower	20	200	Y	244

Sample Calculation

Analysis of the different ways the joint failed

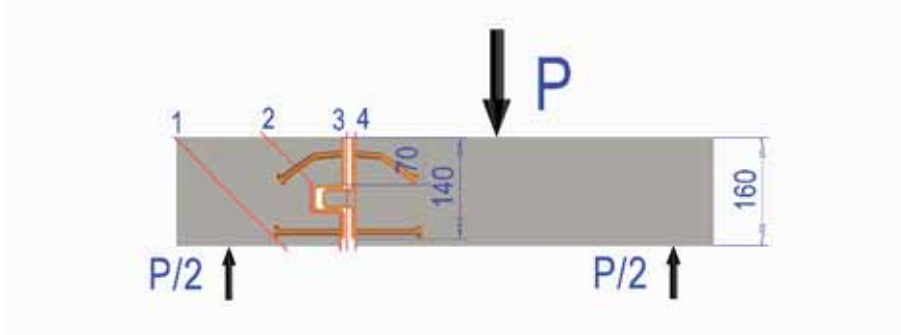

Technical data

- Concrete thickness H: 160 mm
- Height of the profile: h= 140 mm.
- Anchor failure strength: $\sigma_{\text{ank}} = 450 \text{ N/mm}^2$
- Failure strength of steel $\sigma_{\text{st}} = 350 \text{ N/mm}^2$
- Characteristic compression strength of the concrete $f_{\text{ck}} = 25 \text{ N/mm}^2$
- Anchor diameter $\phi 10 \text{ mm}$
- Load transfer 50%
- P = force per length unit
- n_{ank} = Number of anchors per length unit
- ζ = shear stress

Different ways of failure

Hc-Omega with one row of anchors

1. Failure of the concrete due to shear:

$$P = 1/\text{Load transfer} * H * \sqrt{2} * \zeta \quad \text{where } \zeta = 0.05 * f_{\text{ck}} / 1.5$$

$$P = 1/0.5 * 160 * \sqrt{2} * 0.05 * 25 / 1.5 \\ = 377 \text{ kN}$$

2. Failure of the anchors on the side of the nose

$$P = 1/\text{load transfer} * (a * \sqrt{2} * \zeta + A_{\text{ank}} * n_{\text{ank}} * \zeta_{\text{ank}})$$

$$\text{where } \zeta_{\text{ank}} = 0.8 * \sigma_{\text{ank}}$$

$$P = 1/0.5 * (70 * \sqrt{2} * 0.05 * 25 / 1.5 + 10^2 * \pi/4 * 6 * 0.8 * 0.45)$$

$$P = 504 \text{ kN}$$

3. Failure of the profile

$$P = 1/\text{load transfer} * A * \zeta_{st}$$

where $\zeta_{st} = 0.8 * \sigma_{st}$

$$P = 1/0.5 * (5 * 4 * 0.8 * 350)$$

$$P = 11,200 \text{ kN}$$

4. Failure of the anchors on the flat side

$$P = 1/\text{load transfer} * (a * \zeta + A_{ank} * n_{ank} * \zeta_{ank})$$

where $\zeta_{ank} = 0.8 * \sigma_{ank}$

$$P = 1/0.5 * (20 * 0.05 * 25 / 1.5 + 10^2 * \pi/4 * 6 * 0.8 * 0.45)$$

$$P = 372 \text{ kN}$$

For the given example, the load applied along the joint could reach 372 kN taking into account that 50% of this charge is transferred.

Hc-Omega with two rows of anchors

1. Failure of the concrete due to shear:

$$P = 1/\text{Load transfer} * H * \sqrt{2} * \zeta \quad \text{where } \zeta = 0.05 * f_{ck} / 1.5$$

$$P = 1/0.5 * 160 * \sqrt{2} * 0.05 * 25 / 1.5$$

$$= 377 \text{ kN}$$

2. Failure of the anchors on the side of the nose

$$P = 1/\text{load transfer} * (a * \sqrt{2} * \zeta + A_{ank} * n_{ank} * \zeta_{ank})$$

where $\zeta_{ank} = 0.8 * \sigma_{ank}$

$$P = 1/0.5 * (70 * \sqrt{2} * 0.05 * 25 / 1.5 + 10^2 * \pi/4 * 10 * 0.8 * 0.45)$$

$$P = 730 \text{ kN}$$

3. Failure of the profile

$$P = 1/\text{load transfer} * A * \zeta_{st}$$

where $\zeta_{st} = 0.8 * \sigma_{st}$

$$P = 1/0.5 * (5 * 4 * 0.8 * 350)$$

$$P = 11,200 \text{ kN}$$

4. Failure of the anchors on the flat side

$$P = 1/\text{load transfer} * (a * \zeta + A_{ank} * n_{ank} * \zeta_{ank})$$

where $\zeta_{ank} = 0.8 * \sigma_{ank}$

$$P = 1/0.5 * (20 * 0.05 * 25 / 1.5 + 10^2 * \pi/4 * 10 * 0.8 * 0.45)$$

$$P = 598 \text{ kN}$$

For the given example, the load applied along the joint could reach 598 kN taking into account that 50% of this charge is transferred. However the failure of the concrete will be at 377 kN

The values given in this example are only indicative values and must always be verified by a structural engineer.

The safety factors must be chosen in function of the application and rulings.
Higher safety factors must be used for dynamic loads than for static loads.
For floors on piles, we always recommend expansion joints with two rows of anchors.

Installation instruction

The floor slab should be divided into square sections as much as possible. If this is not possible, the proportion of 3/2 for the width/length of the floor slab should be respected as much as possible.

The distance between the joints is determined in function of the expected shrinkage of the concrete. The shrinkage of a floor slab is strongly dependent on a number of thermal variables as well as the quality of the concrete. Shrinkage can vary between 0,3 to 0,5 mm/meter. In any case, an attempt must be made to limit the opening of the joints to a maximum of 20 mm. An indication in normal conditions would be floor sections of 30 to 40 metres. However, the advice of the project leader or expert is always recommended because shrinkage can vary considerably from country to country due to local environmental factors and concrete quality.

For intensively loaded floor sections, such as floors at loading bays and thoroughfares, we advise the use of the patent pending Sinus Slide® joint. The added cost is minimal relative to the total project investment, and is quickly recovered in view of the many advantages. Only with savings on the replacement costs of forklift's wheels the payback period is less than one year.

Fixed structures in the building such as columns and walls must be isolated with compressible material.

Ensure that no fixed connections are placed between 2 different floor slabs that could hinder the movement of these floor slabs, e.g. racks, conveyor belts, crash barriers, etc.

For some floors that are placed on a watertight membrane or insulation for example, the use of anchoring in the ground is not permitted. As an alternative we have adjustable placement feet available or other custom made solutions in our product range that do not require drilling through the foundation.

For floors on supporting piles, we always advise dilatation joints with a double row of anchors.

Check the presence of utilities and underground lines when using anchoring with pins in the ground.

A demonstration video of these installation instructions is available on our website at www.hcjoins.eu. This can be found on the page PROFILES / HC-O joint.

1. String a line in the location where the profiles are to be installed.
2. Lay the joints out along this line.
3. Place the first joint parallel to this line.
4. Bring them to the correct height using wedges or the height adjustment tool. (See accessories)
5. Hammer or drill pins into the ground vertically along the ends of the anchors with 2 on each side of the end of the profile. If desired, an additional pin can be placed in the middle of the profile.
6. Check the height level of the profile with a laser and check the alignment relative to the taut line.
7. Use a spirit level to check the levelness of the profile across the length.
8. Weld the pins to the profile. If welding work is not permitted on site, special adjustment feet are available.
9. Place the next profile with its overlap in the first profile. With the overlapping, the start of this profile is immediately at the correct height.
10. Bring the end of the second profile to the correct height with wedges or the height adjustment tool.
11. Repeat these steps from point 5 until an intersection, wall or column is reached.

For intersections:

1. Place the intersection in the location specified on the layout plan.
2. Measure the distance between the last placed joint and the intersection. Cut the joint to be placed to the correct length using a cutting disc.
3. Place the joint that has been cut to length according to the procedure described above.
4. Bring the intersection to the correct level and weld it to the joint. Remember to weld the supplied noses on to prevent the penetration of poured concrete into the joint.

Maintenance and finishing

The HC-Omega dilatation joint is designed to protect the edges of concrete slabs that are automatically formed when the joint opens due to the shrinkage that occurs in the drying process.

We advise filling the openings that are created with a joint or sealing product to prevent the accumulation of dirt and dust in the joint. Sealing the joint is possible for traditional HC-Omega joints as for HC-Omega Sinus Slide® Joint. **The final sealing may only be done once the expansion of the joint is stabilised.**